

Determining the number of cores in multimode optical fibers for communication

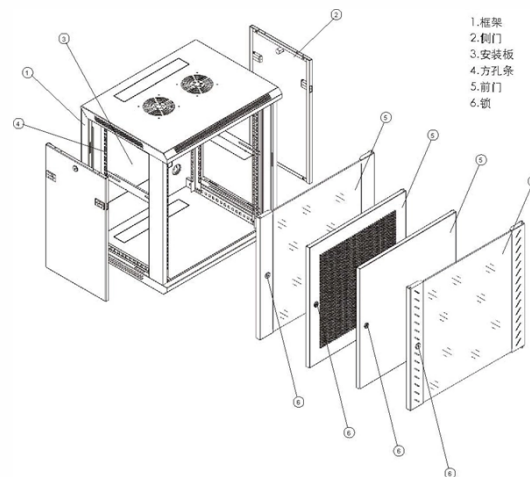

Overview

The number of optical cores in an optical fiber is the total number of equipment interfaces multiplied by 2, plus 10% to 20% of the spare quantity, and if the communication mode of the equipment has serial communication and equipment multiplexing, you can reduce the number of cores. This Applications Engineering Note (AE Note) discusses the criteria for properly selecting the optimal multimode fiber (MMF) for enterprise applications. Multimode fibers are fibers having multiple guided modes at the operating wavelength — sometimes only a few (→ few-mode fibers), but often many. However, the manufacturing technology of multi-core fiber is still in its early stages, facing. Fiber optic cables consist of multiple thin strands of glass or plastic, known as “cores.” These cores carry the data signals via light. The number of cores you choose directly impacts the capacity and. Common fiber cores include 1 core, 2 cores, 6 cores, 8 cores, etc.



Article Content

Oct 07, 2025

Multicore Fiber

1.3 Multicore fibers An MCF is an optical fiber that includes multiple cores in one common cladding. MCFs offer more degrees of freedom in fiber parameters than single-core fibers, which implies that

Mar 15, 2026

Multimode Optical Fiber Selection & Specification

Another consideration in choosing the correct fiber for a network is compatibility with any incumbent fiber that may already be installed (known as “legacy” fiber).

Mar 30, 2026

Multimode Fibers: A Comprehensive Guide

Explore the world of multimode fibers, their characteristics, advantages, and uses in various optical and photonic applications.

Jun 02, 2026

Applications and Development of Multi-Core Optical

Researchers are exploring how to achieve higher core numbers and larger transmission capacities. The introduction of Spatial Division Multiplexing

Nov 01, 2025

Multi-Core Optical Fibers for the Next-Generation Communications

Since the very beginning of the SDM R&D, we have continuously contributed both to revealing the behavior and characteristics of the optical properties—such as inter-core crosstalk— of MCFs, and to

Sep 20, 2025

Multimode Fiber

Multimode fibers are simultaneously an old and emerging technology within the context of optical systems. The first optical fiber systems back in the 1970s used multimode fibers. These fibers are

Dec 20, 2025

What is sfp optical transceiver?

Multimode SFP Transceivers: These transceivers are designed for multimode fiber cables, which have a larger core diameter and are suitable for short-distance communication. Multimode SFPs are

Jun 10, 2026

Single-Mode Fiber (SMF) vs Multimode Fiber (MMF):

For example, Plastic Optical Fiber (POF) comprises a plastic core, which offers an increased bend radius for compact installations. However, POF is

Nov 12, 2025

A Guide to Multimode Fiber Types (OM1-OM5) -

Multimode fiber is a kind of optical fiber mostly used in communication over shorter distances, for example inside a building or for the campus.

Jul 10, 2025

Single Mode vs Multimode Fiber, What is The

In this in-depth single mode vs. Multimode Fiber comparison, I will compare those two fiber optic cables, helping you learn the difference and

Apr 02, 2026

A review on coupled and uncoupled multicore fibers for future ultra ...

Various limitations in realizing efficient few mode multicore fiber (FM-MCF) design are analyzed in this paper. For both types of fibers, achievable spatial channel count, crosstalk and

Sep 12, 2025

How to determine the number of cores required when using fiber optic?

The number of fiber cores is mainly related to the device interface of the fiber connection and the communication mode of the device. Generally speaking, the number of optical cores in an optical

Mar 16, 2026

Applications and Development of Multi-Core Optical

The rapid development of information and communication technology has driven the demand for higher data transmission rates. Multi-core optical fiber,

May 13, 2026

Multi-Core Optical Fibers: Theory, Applications and

Multi-core fibers (MCFs) have sparked a new paradigm in optical communications, as they can significantly increase the Shannon capacity of

Feb 03, 2026

Passive and active optical fibers for space and terrestrial applications

All the aforementioned applications rely heavily on the use of onboard photonic devices and systems. Silica optical fibers are used in fiber lasers, fiber amplifiers, fiber sensors, etc. They are also used in

Jul 31, 2025

Multimode Fiber: A Comprehensive Guide

Discover the world of multimode fiber, its types, advantages, and applications in modern optical communication systems.

May 20, 2026

How to choose the number of fiber cores?

Common fiber cores include 1 core, 2 cores, 6 cores, 8 cores, etc., and there are many types. This article will focus on the number of fiber cores,

Sep 11, 2025

Effect of Core Geometry on Frequency Correlations and Channel

Photons are the fundamental carriers of classical and quantum information across long distances via optical fibers. Multimode fibers with many transverse optical modes can support high

Jun 04, 2026

Everything You Need to Know About Multimode Fiber

Explore multimode fiber optic cables for enterprise, campus, and data center networks. Learn about OM1-OM5 types, transmission ranges, installation

Aug 06, 2025

How Many Core In Fiber Optic Cable Do I Need

Generally speaking, the number of optical cores in an optical fiber is the total number of equipment interfaces multiplied by 2, plus 10% to 20% of the

Oct 21, 2025

How to Choose the Suitable Number of Fiber Cores for

Fiber optic cables are the backbone of modern communication systems, offering high-speed data transmission over long distances with minimal

Apr 21, 2026

(PDF) Multi-core Fiber Technology

This chapter describes the recent progress on the Multi-core fibers technology for the application of high capacity space-division multiplexing to be

Nov 24, 2025

Tutorial Passive Fiber Optics, Part 4: Multimode Fibers

A basic specification of a multimode fiber contains its core and outer diameters. Common telecom fibers (fibers for optical fiber communications over moderate

May 05, 2026

How to Choose the Suitable Number of Fiber Cores for

When designing or upgrading your network infrastructure, one of the most important decisions you'll face is choosing the appropriate number of fiber

Contact Us

For more information, pricing, or custom solutions, please contact us:

Website: <https://elagage-lorrain.fr>

Email: sales@elagage-lorrain.fr

Phone: +33 6 47 82 19 35

Address: 15 Rue de la République, 69002 Lyon, France

This document is for informational purposes only. Specifications subject to change without notice.

